

# STRINGABLE TENT LIGHTS

## Relamping Instructions

Use Replacement Light Kit # 31-1-50



Model No. 31-5004M  
NSN 6230-01-483-7562



Model No. 31-502SK  
NSN 6230-01-465-8931

1. Remove wire/cable tie from smaller end cap located opposite handle. Do not remove handle.
2. Remove strain relief nut and sleeve from strain relief then remove end cap by gently prying off tube with a screwdriver or similar tool. Do not loosen jam nut.
3. Carefully remove shock, using care not to pull on cord. On Model 31-502SK do not remove screen when removing shock.
4. Grasp bulb puller and gently but firmly pull bulb out of socket and remove from outer tube. Take care since bulb is tightly wedged in socket.
5. Remove bulb puller from old bulb and dispose of bulb properly. If old bulb is not broken, there is a vacuum inside and breaking the bulb can be dangerous.
6. Clean inside of outer tube if necessary.
7. Install bulb puller on new bulb as shown. This will assist in removing bulb the next time.
8. Slide new bulb/bulb puller into outer tube and align so pins will intersect with receiver holes in socket. On Model 31-502SK do not pull on metal braid.
9. Gently push bulb down into socket and seat pins in receiver holes.
10. Plug light in and activate switch. Ensure bulb is seated properly and that it illuminates.
11. Replace shock, using care not to pull on cord or screen.
12. Replace end cap, making certain cap is fully seated in groove of tube. Secure with a 150-lb. minimum cable/wire tie.

### WARNING

WEAR HAND AND EYE PROTECTION  
DISCONNECT POWER SOURCE

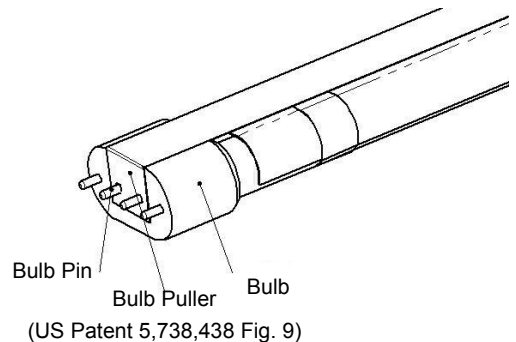
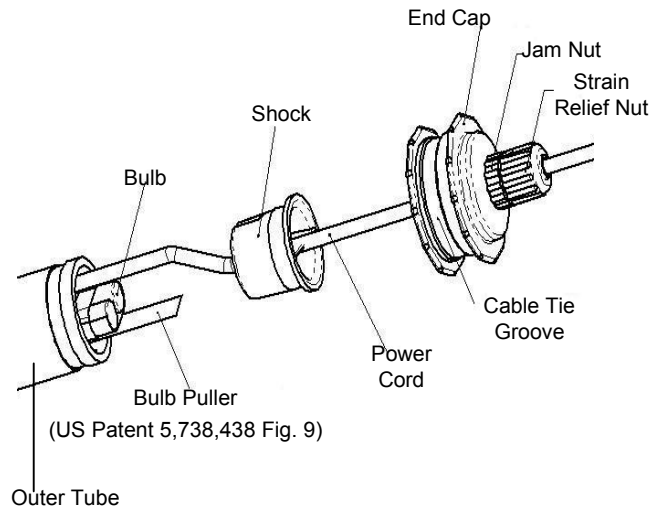

800.346.1956

www.jamesoncorp.com